



**SZENT ISTVÁN  
EGYETEM**



**GÉPÉSZMÉRNÖKI KAR • GÖDÖLLŐ**

## **NAPENERGIA HASZNOSÍTÁS hazai és nemzetközi helyzetkép**

**60. Országos Fizikatanári Ankét és Eszközbemutató**

**Szent István Egyetem, Gödöllő, 2017. március 15.**

---

**Prof. Dr. Farkas István**

Szent István Egyetem, KÖRI Fizika és Folyamatirányítási Tanszék

Páter K. u. 1., H-2100 Gödöllő

Tel.:+36 28 522055, Email: [Farkas.Istvan@gek.szie.hu](mailto:Farkas.Istvan@gek.szie.hu)



# Tartalom

**Bevezetés**

**Jelenlegi helyzetkép, szenáriók**

**Prioritások a napenergia-hasznosításban**

**A napenergia hasznosítás kiemelt területei**

- **fototermikus**
- **fotovillamos**
- **passzív**

**Integrált szoláris energetikai/technológiai rendszer**

**Referenciák**

**Összefoglalás**





# Bevezetés

## Magyar Napenergia Társaság

## ISES Napenergiás Világkongresszus 2015

### Háttérinformációk

- **Renewables 2015 – Global Status Report**
- **RE-thinking 2050 – A 100% Renewable Energy Vision for EU**
- **REthinking Energy 2015**
- **IEA Wolds Energy Outlook 2013**
- **Strategic research priorities for solar thermal technology**
- **Solar district heating – 2012**
- **Current status of solar thermal application worldwide**
- **Solar Heat Worldwide – 2015**





# Magyar Napenergia Társaság

## Szakcsoportok:

- **Napenergia építészeti hasznosítása**
- **Napenergia fotovillamos hasznosítása**
- **Napenergia mezőgazdasági hasznosítása**
- **Napenergia hőhasznosítása**
- **Energiapolitika**
- **Szoláris hőszivattyúk**





# ISES Napenergiás Világkongresszus 2015



The [International Solar Energy Society \(ISES\)](#) and the [Korean Solar Energy Society \(KSES\)](#) are pleased to invite you to the [ISES Solar World Congress 2015](#) which will be taking place in Daegu, Korea from 8 – 12 November 2015. Join us for this unique opportunity to present and share your work, connect with the international renewable energy community and learn about the latest in renewable energy developments world-wide.

## Range of topics under the Congress themes.



- Solar Buildings and Architecture
- Resource Assessment and Energy Meteorology
- Renewable Electricity Technologies: PV
- Renewable Electricity Technologies: CSP, Biomass, Geothermal, Wind, Hydro, Ocean and Other
- Solar Heating and Cooling
- Solar Energy and Society
- Energy Storage
- Renewable Energy Grid Integration and Distribution
- Off-Grid and Rural Energy Access
- Clean Transportation Technologies and Strategies

A conference of:



Hosted by:





SZENT ISTVÁN  
EGYETEM

GÉPÉSZMÉRNÖKI KAR  
GÖDÖLLŐ

# Renewables 2015 - Global Status Report





SZENT ISTVÁN  
EGYETEM

GÉPÉSZMÉRNÖKI KAR  
GÖDÖLLŐ

# RE-thinking 2050

## A 100% Renewable Energy Vision for the EU

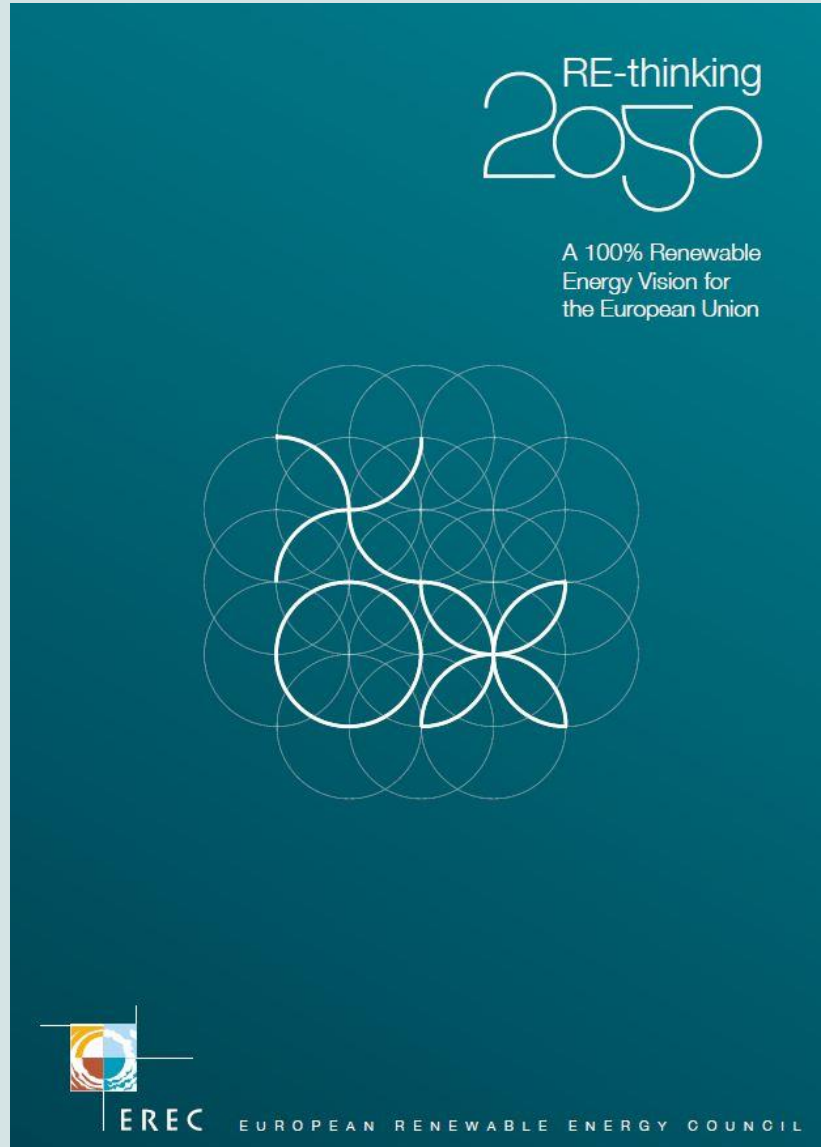



SZENT ISTVÁN  
EGYETEM

GÉPÉSZMÉRNÖKI KAR  
GÖDÖLLŐ

# RE-thinking Energy 2015

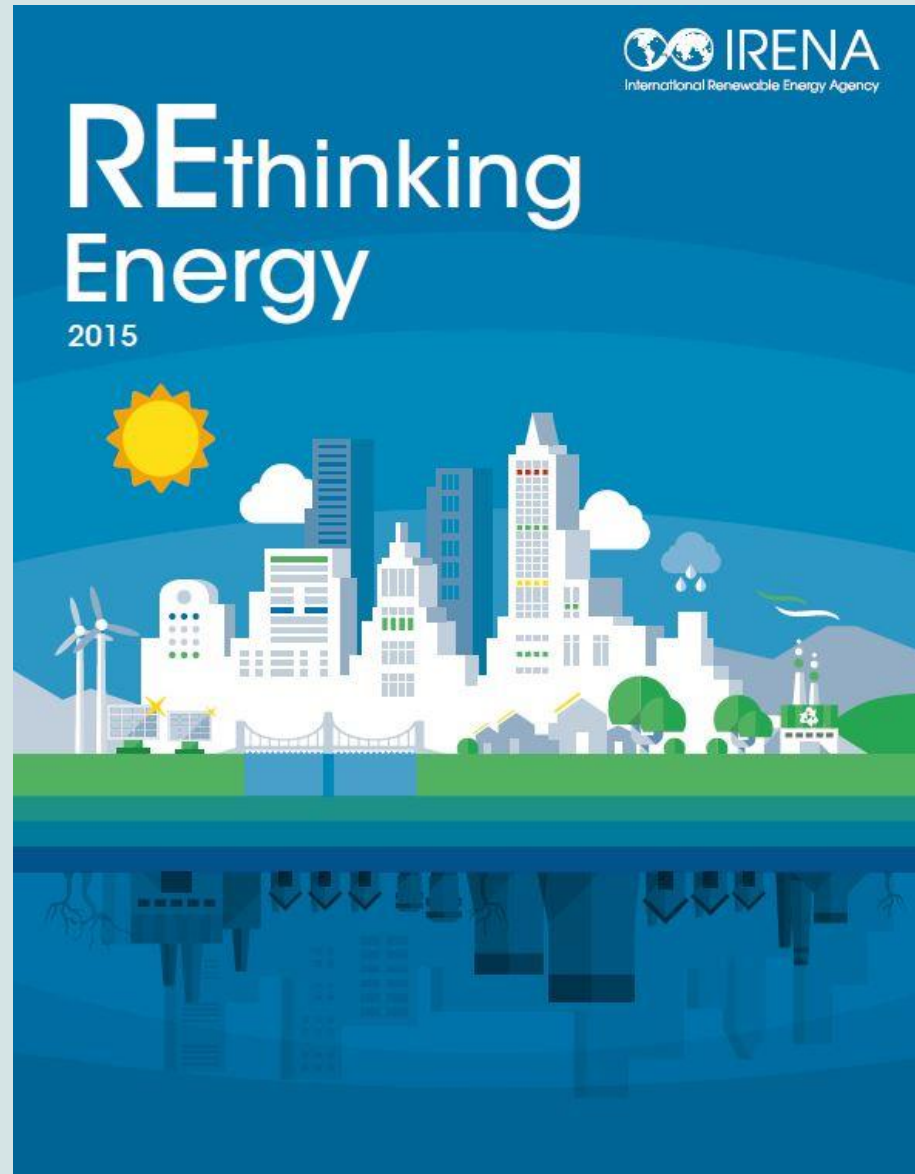





SZENT ISTVÁN  
EGYETEM

GÉPÉSZMÉRNÖKI KAR  
GÖDÖLLŐ

# World Energy Outlook 2013



*Please note that this PDF is subject to specific restrictions that limit its use and distribution. The terms and conditions are available online at <http://www.iea.org/termsandconditionsuseandcopyright/>*

# WORLD ENERGY OUTLOOK

2 0 1 3



# Strategic Research Priorities for Solar Thermal Technology



SZENT ISTVÁN  
EGYETEM

GÉPÉSZMÉRNÖKI KAR  
GÖDÖLLŐ

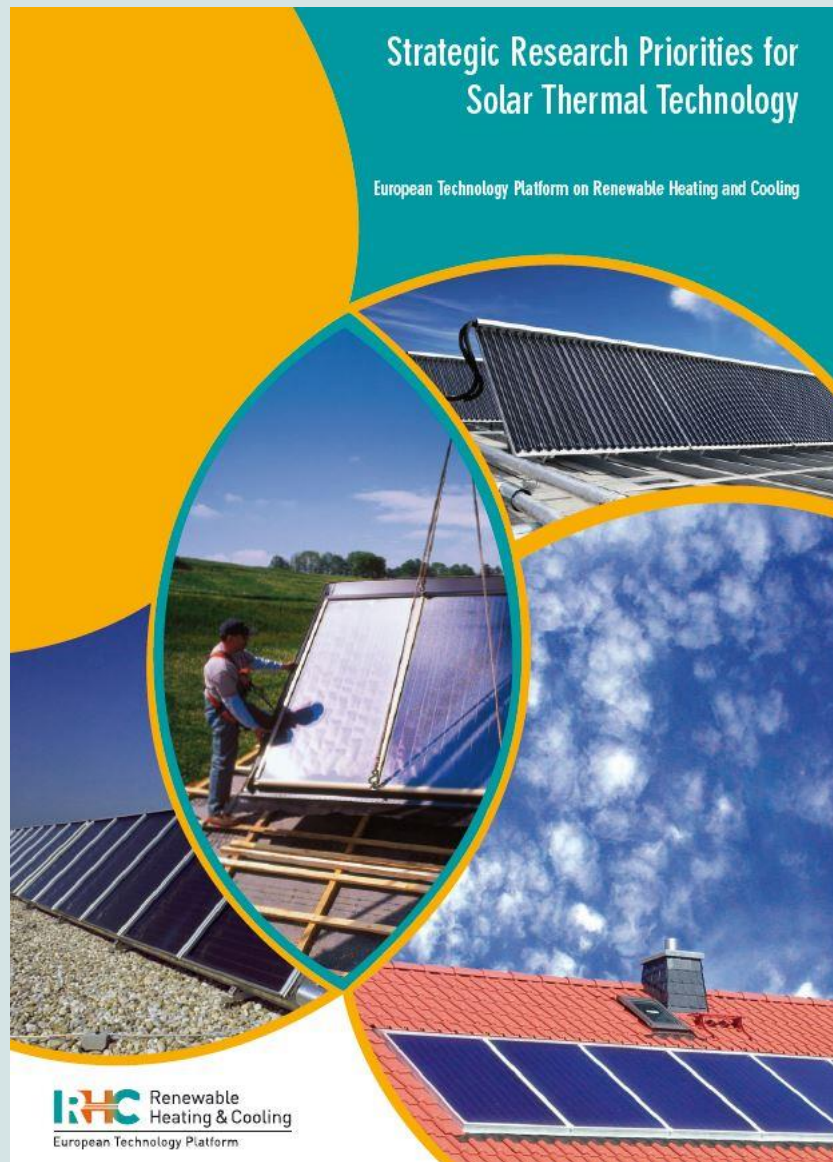



SZENT ISTVÁN  
EGYETEM

GÉPÉSZMÉRNÖKI KAR  
GÖDÖLLŐ

# Solar District Heating



**SDH**  
solar district heating

**Market for Solar  
District Heating**

by

CIT Energy Management AB

This project is supported by:



# Current Status of Solar Thermal Application Worldwide



SZENT ISTVÁN  
EGYETEM

GÉPÉSZMÉRNÖKI KAR  
GÖDÖLLŐ



## Current Status of Solar Thermal Application Worldwide

**Werner Weiss**

**AEE - Institute for Sustainable Technologies**  
A-8200 Gleisdorf, Feldgasse 2  
AUSTRIA





SZENT ISTVÁN  
EGYETEM

GÉPÉSZMÉRNÖKI KAR  
GÖDÖLLŐ

# Solar Heat Worldwide

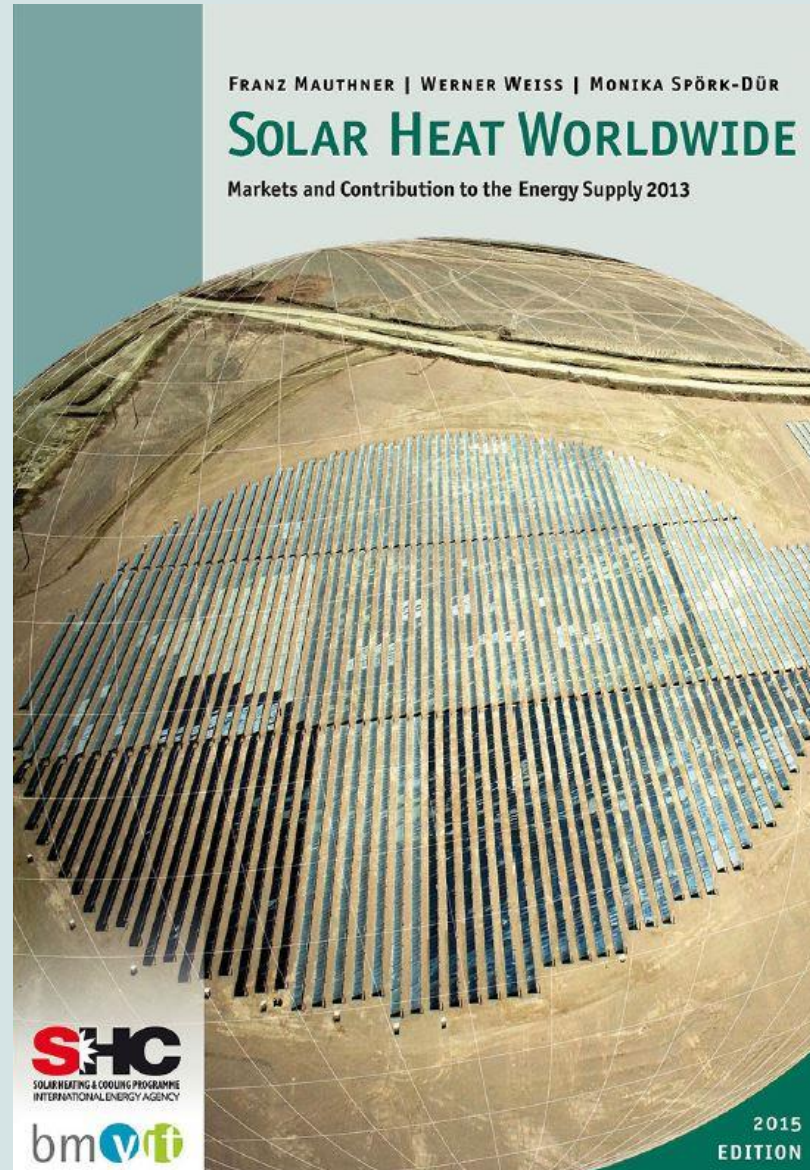



# Jelenlegi prioritások a napenergia hasznosításban

**Termikus napenergia-hasznosítás - kisebb prioritású**

**Villamos energia előállítása koncentrált termikus rendszerrel – támogatott**

**Fotovillamos napenergia-hasznosítás – magasabb prioritású**

**Passzív hasznosítás – folyamatos ütemű**



# Termikus napenergia-hasznosítás kiemelt területek



SZENT ISTVÁN  
EGYETEM

GÉPÉSZMÉRNÖKI KAR  
GÖDÖLLŐ



**Figure 1:** From countries shown in yellow detailed market data are available.  
The market data from all other countries are estimated.



# Termikus napenergia kapacitás és energiatermelés



SZENT ISTVÁN  
EGYETEM

GÉPÉSZMÉRNÖKI KAR  
GÖDÖLLŐ

Capacity [ $\text{GW}_{\text{th}}$ ], Energy [TWh]

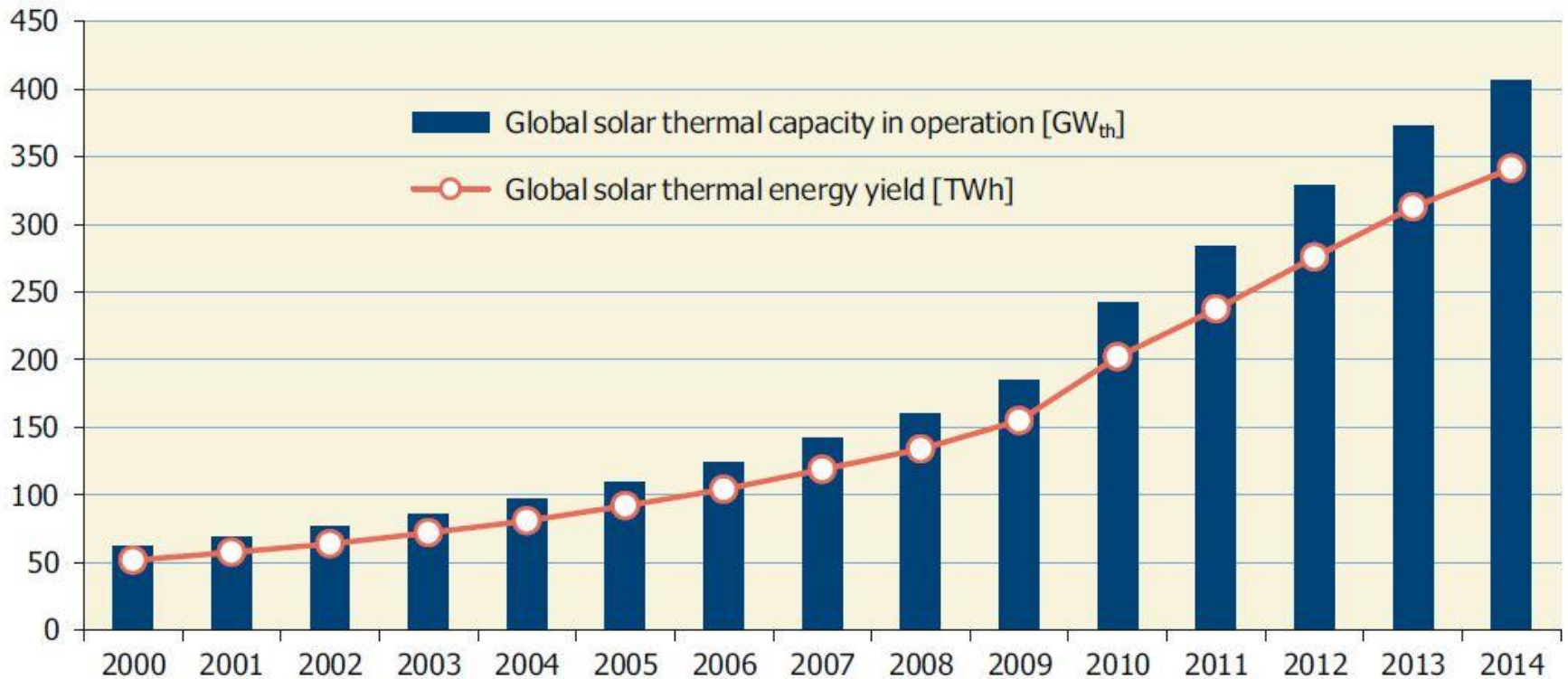



# Megújuló energiaforrások kapacitás és energiatermelés



SZENT ISTVÁN  
EGYETEM

GÉPÉSZMÉRNÖKI KAR  
GÖDÖLLŐ

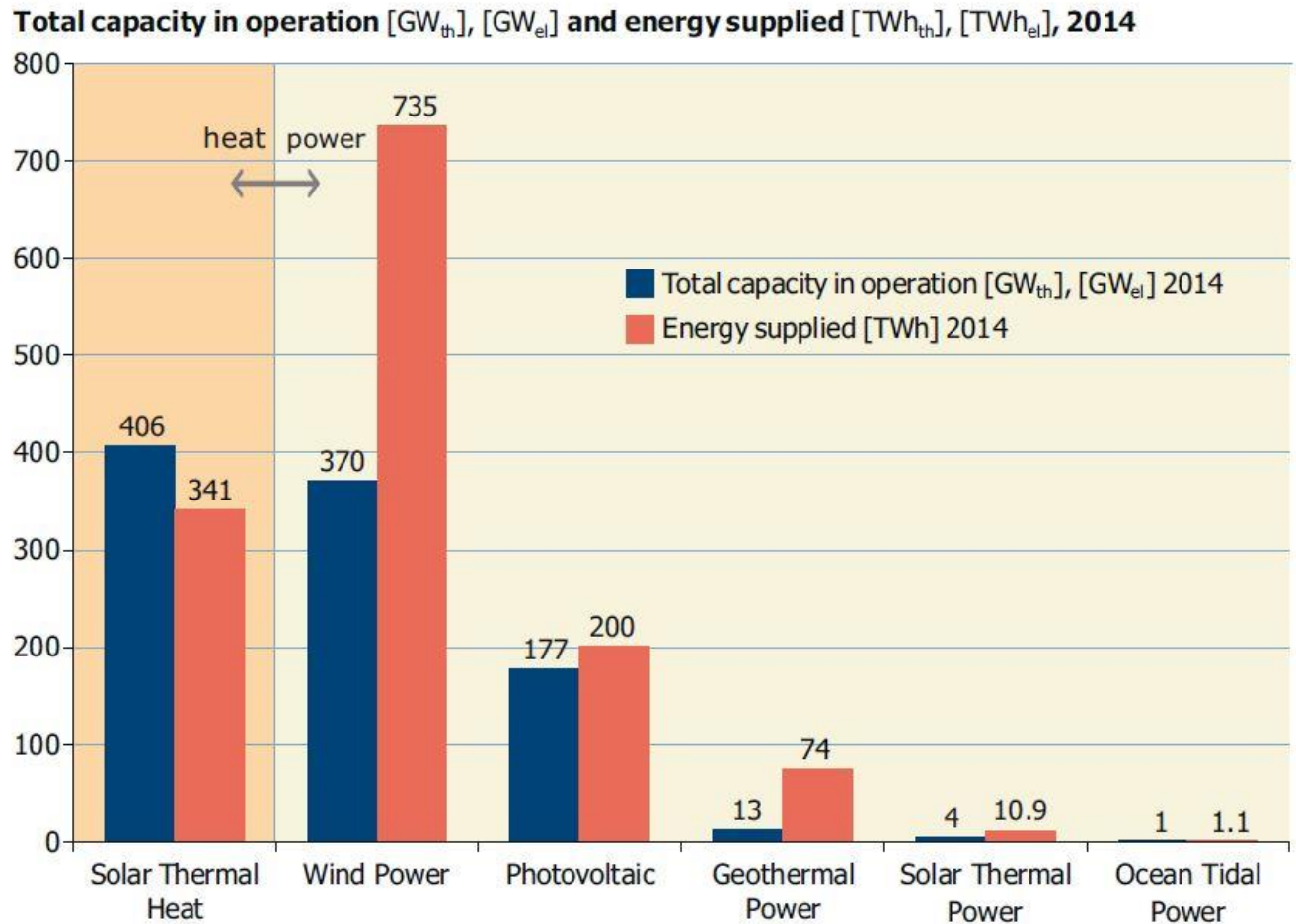

**Figure 3:** Global capacity in operation [ $\text{GW}_{\text{el}}$ ], [ $\text{GW}_{\text{th}}$ ] 2014 and annual energy yields [ $\text{TWh}_{\text{el}}$ ], [ $\text{TWh}_{\text{th}}$ ] (Sources: AEE INTEC, Global Wind Energy Council (GWEC), European PV Industry Association (EPIA), REN21 - Global Status Reports 2014 and 2015)





# Megújuló energiaforrások piaci növekedésének üteme

SZENT ISTVÁN  
EGYETEM

GÉPÉSZMÉRNÖKI KAR  
GÖDÖLLŐ

Total capacity in operation [ $\text{GW}_{\text{th}}$ ,  $\text{GW}_{\text{el}}$ ]

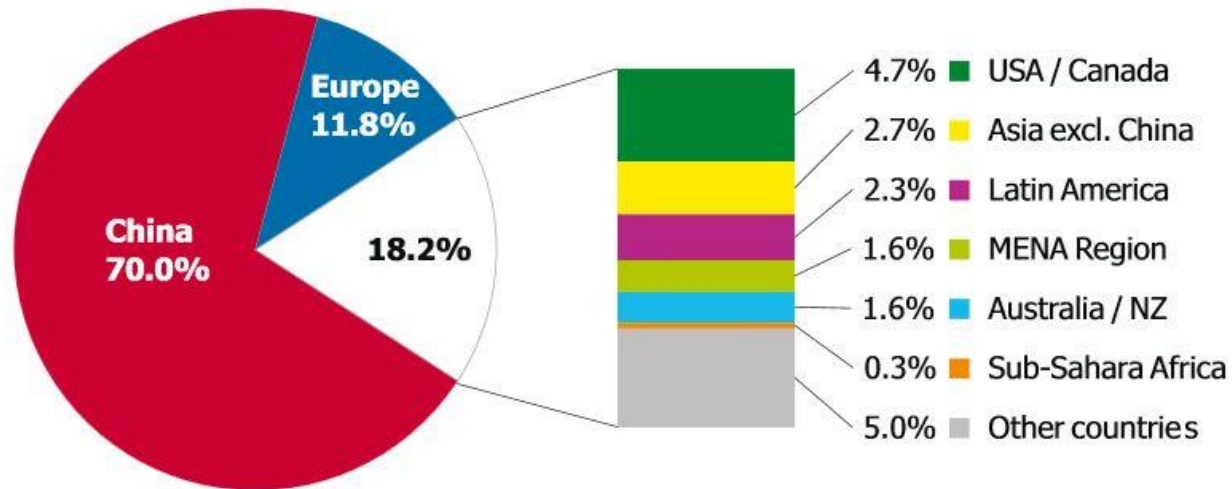

**Figure 4:** Global solar thermal heat, wind power and photovoltaic capacity in operation and market growth rates between 2010 and 2014

(Sources: AEE INTEC, Global Wind Energy Council (GWEC), European PV Industry Association (EPIA), REN21)



# Napkollektoros rendszerek eloszlása



Sub-Saharan Africa:

Asia excluding China:

Latin America:

Europe:

MENA Region:

Mauritius, Mozambique, Namibia, South Africa, Zimbabwe

India, Japan, Korea South, Taiwan, Thailand

Barbados, Brazil, Chile, Mexico, Uruguay

EU 28, Albania, Macedonia, Norway, Russia, Switzerland, Turkey

Israel, Jordan, Lebanon, Morocco, Palestinian Territories, Tunisia

**Figure 5:** Share of the total installed capacity in operation (glazed and unglazed water and air collectors) by economic region at the end of 2013



# A termikus napenergia-hasznosítás fejlődése

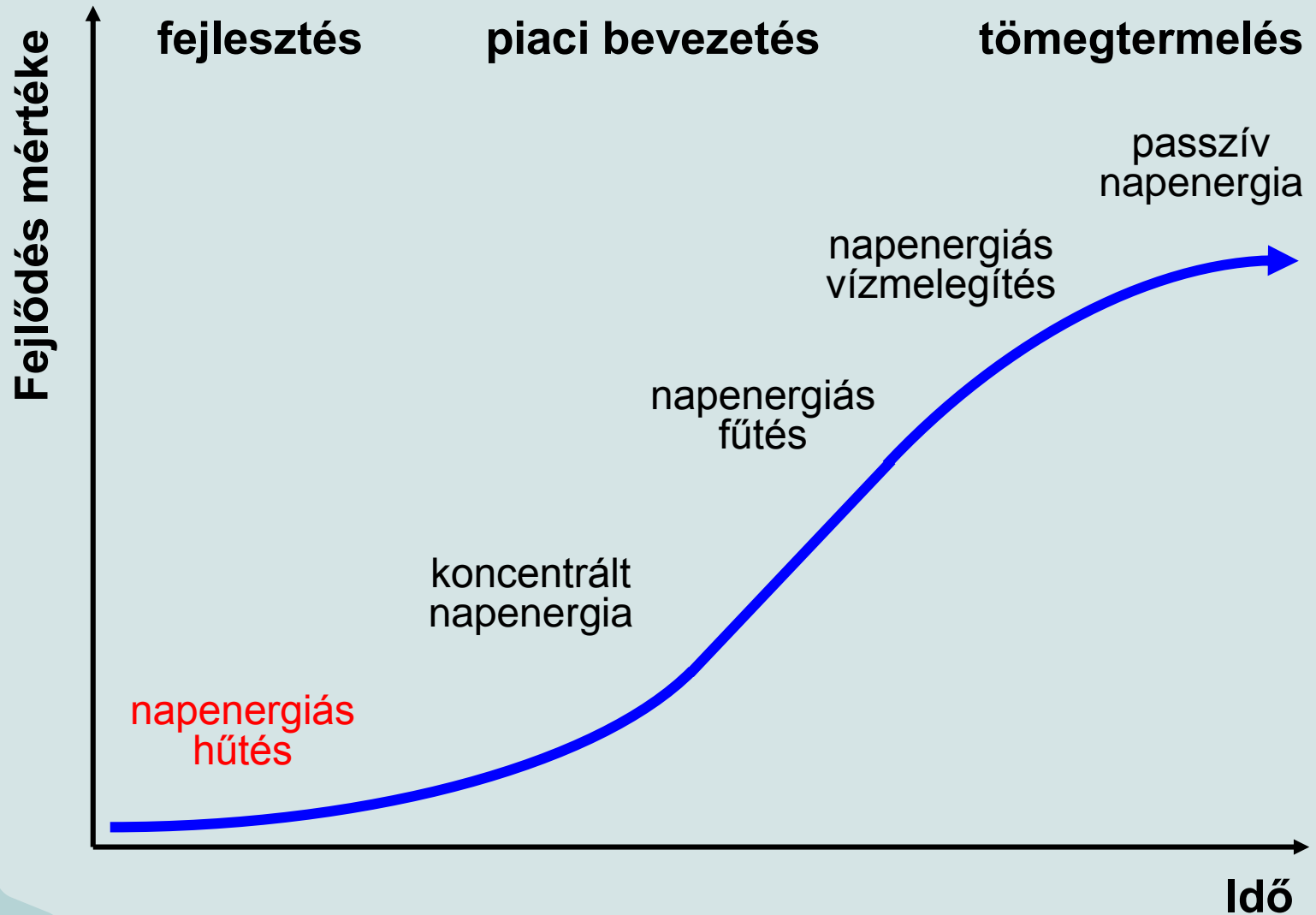



# A termikus napenergia-hasznosítás kiemelt területei

- **használati melegvíz készítés**
- **kombinált rendszerek (HMV – fűtés)**
- **nagy rendszerek**
- **uszodai melegvíz készítés**
- **távfűtés**
- **technológiai melegvíz készítés**
- **napenergiás hűtés**

**EU célkitűzés 2020-ra: 1 m<sup>2</sup> napkollektor/ fő**





# A passzív napenergia-hasznosítás 2030 szenárió

## European Renewable Heating & Cooling Platform (RHC-ETP)

**Új épületek:**

**100%-ban napenergiával fűtött megoldások**

**Felújítandó épületek:**

**50%-ban napenergiával fűtött megoldások**



# Napelem technológiák fejlődése (NREL, 2015)



SZENT ISTVÁN  
EGYETEM

GÉPÉSZMÉRNÖKI KAR  
GÖDÖLLŐ



Napelem cellák laboratóriumban elért legmagasabb hatásfoka

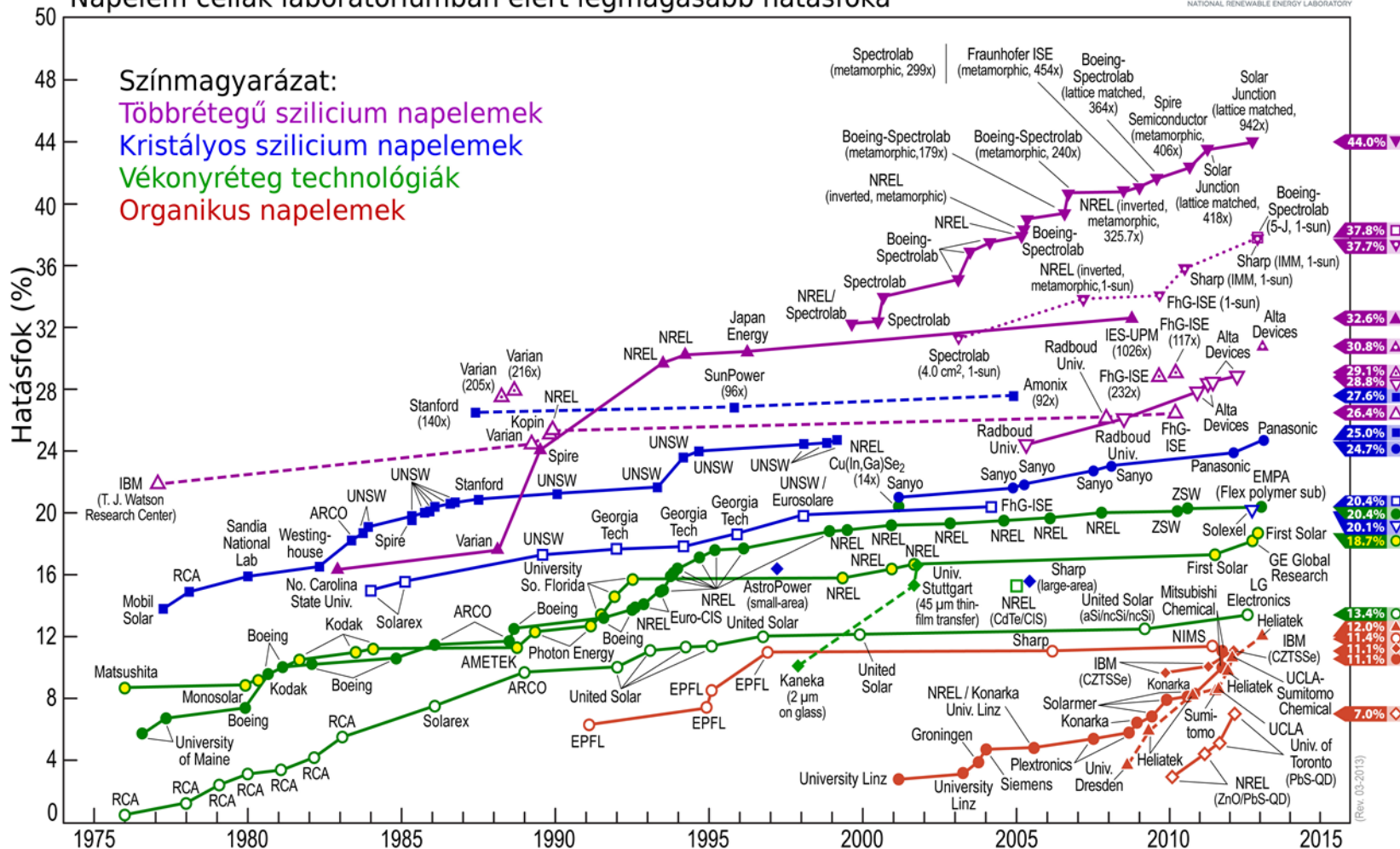

# A fotovillamos napenergia-hasznosítás fontosabb jellemzői

- a PV cellák és modulok 30-40%-os éves árcsökkenése
- a piaci termékek hatásfoka nem nő az elvárt mértékben
- verseny a kristályos és a vékonyrétegű technológiák között
- a több GW teljesítményű kulcsrakész rendszerek elérhetősége
- a kínai termékek jelentős mértékű jelenléte a világpiacon





# Fotovillamos napenergia-hasznosítás fejlesztésének kiemelt területei

- számos új technológia
- harmadik generációs modulok – **organikus PV**
- modulok színezése
- átlátszó modulok
- extra méretű modulok
- új típusú rögzítési rendszerek





SZENT ISTVÁN  
EGYETEM

GÉPÉSZMÉRNÖKI KAR  
GÖDÖLLŐ

# Organikus napelemek

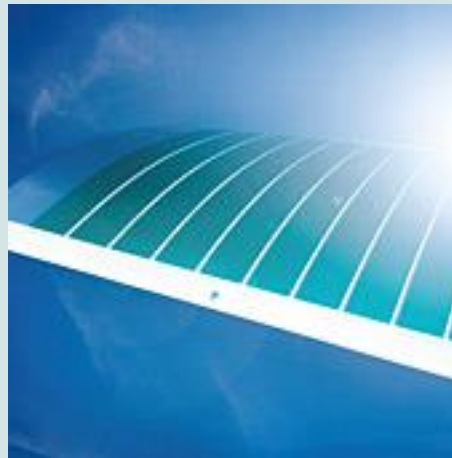
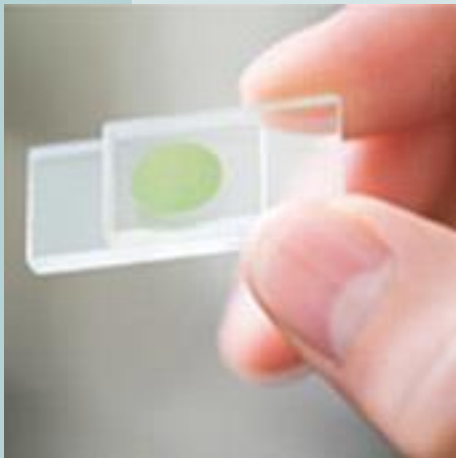



# PV cellák színezése

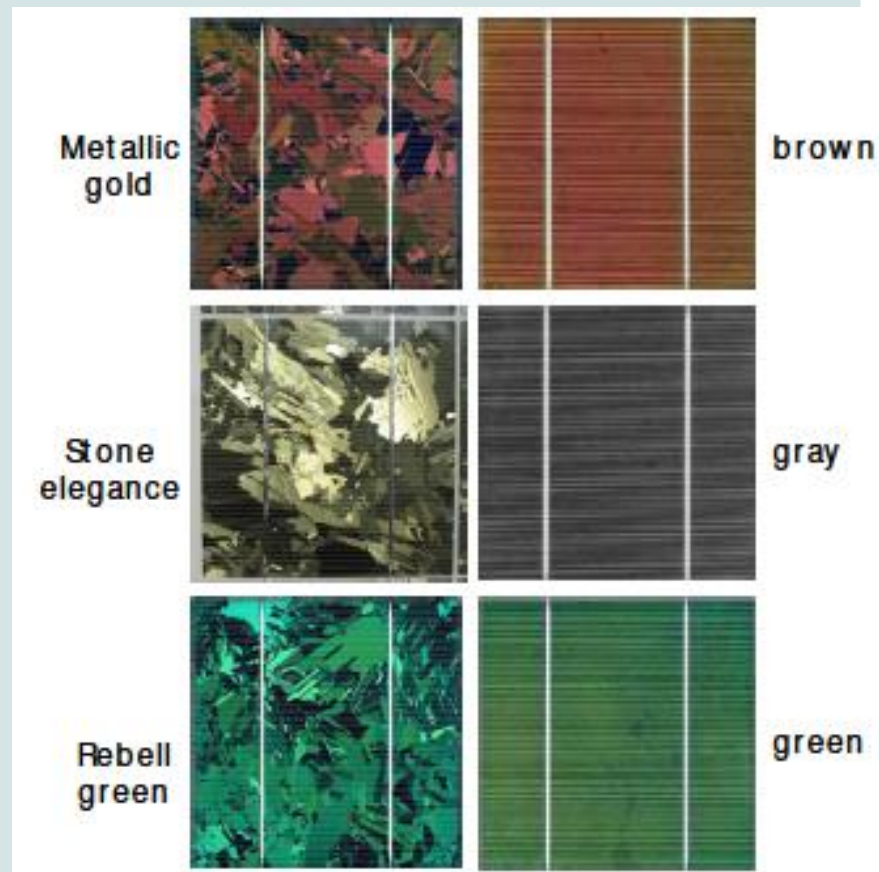
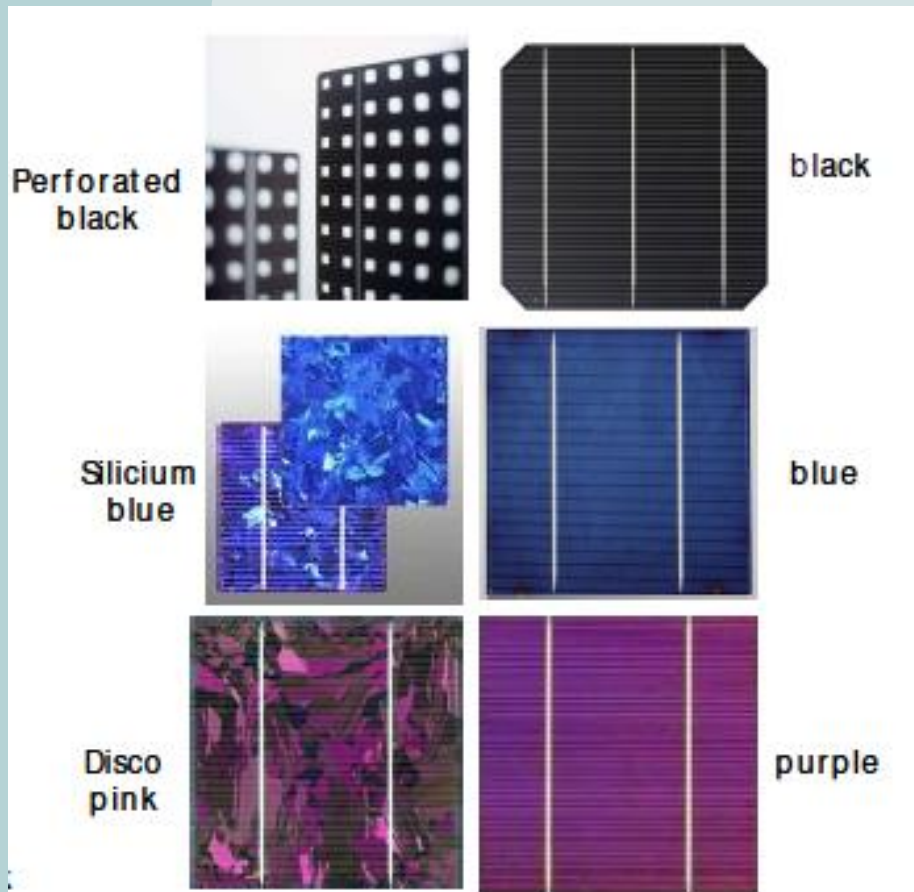



# Áttetsző PV modulok



*Solar powering a green future™*

**SEMI-SHADE™** STP130D - 12/VEC  
Preliminary STP120D - 12/VEC  
Datasheet

## 130 Watt<sub>Maximum Power</sub> Low cost semi transparent module (50% transparency)

Semi-Shade™ is a standard framed solar module with a tempered front glass and durable clear polymer substrate. It can be used to increase natural light levels below the module while still providing shading and power generation.

### Features

- Design is based on a concept from a leading architecture firm specializing in daylighting solution
- Increased light transmission and reduced cost per sq. ft. due to lower cell density
- Utilizes high-efficiency cells based on innovative technologies
- High reliability with guaranteed  $\pm 3\%$  power output tolerance
- Withstands high wind-pressure and snow load
- Discreetly placed junction box closer to the edge of module preserves the sleek and uniform appearance
- Choice of anodized frame color: silver (VEC) or black (VED)

### Quality and Safety

- Rigorous quality control meeting the highest international standards
- ISO 9001:2000 (Quality Management System) and ISO 14001:2004 (Environmental Management System) certified factories manufactures world class products
- Industry leading transferable warranty term
- Conformity with CE, certified to UL1703

### Recommended Applications

- Highly aesthetic carport
- Outdoor canopy
- Other building integrated application





SZENT ISTVÁN  
EGYETEM

GÉPÉSZMÉRNÖKI KAR  
GÖDÖLLŐ

# Modulok új típusú rögzítése





SZENT ISTVÁN  
EGYETEM

GÉPÉSZMÉRNÖKI KAR  
GÖDÖLLŐ

# Új típusú rögzítési módszer

## NVS, Gödöllő, 2014



# Integrált szoláris energetikai/technológia rendszer



SZENT ISTVÁN  
EGYETEM

GÉPÉSZMÉRNÖKI KAR  
GÖDÖLLŐ

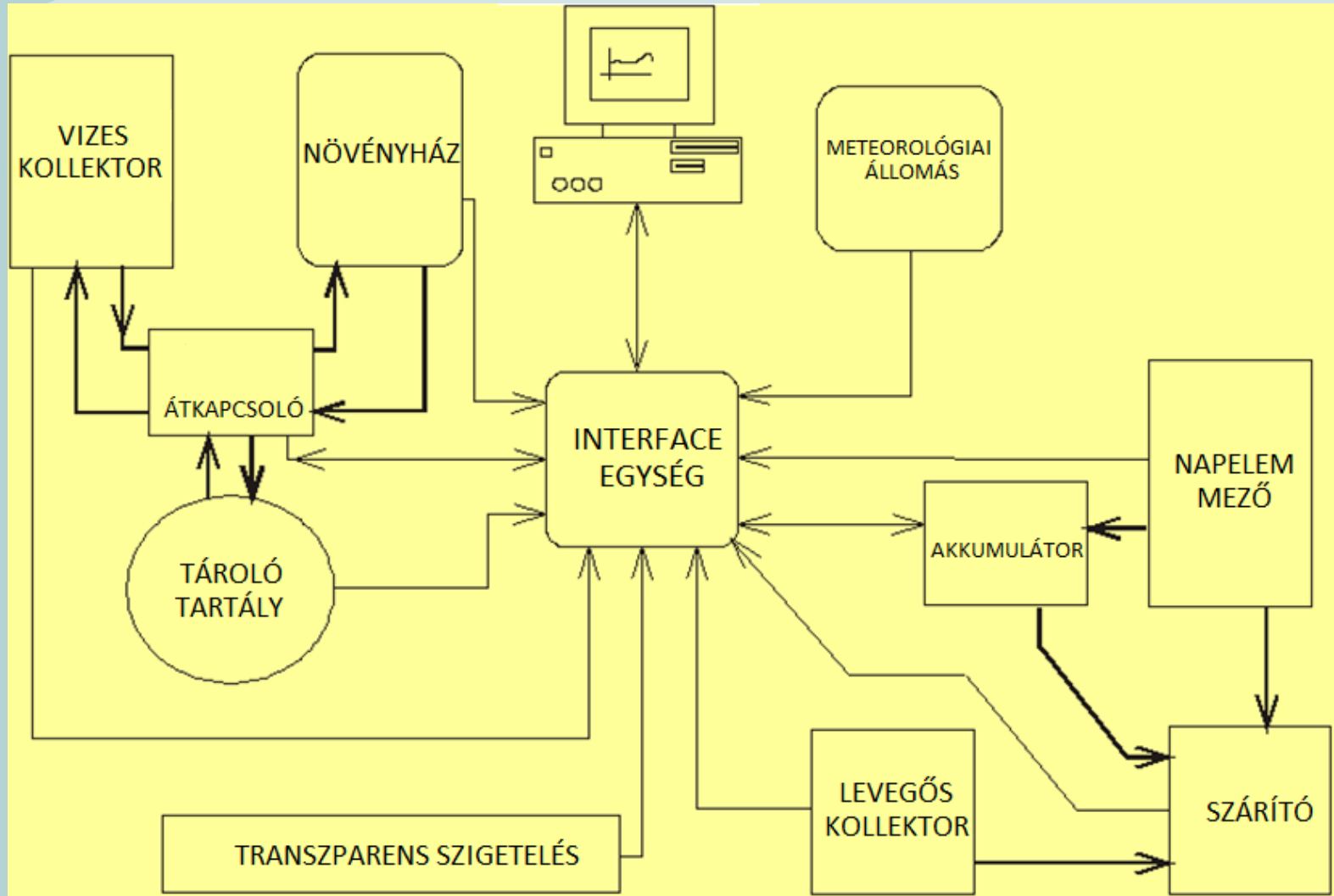



SZENT ISTVÁN  
EGYETEM

GÉPÉSZMÉRNÖKI KAR  
GÖDÖLLŐ

# Családi ház napkollektorral (Gödöllő)





# Napkollektoros úszómedence (SZIE, Gödöllő)



SZENT ISTVÁN  
EGYETEM

GÉPÉSZMÉRNÖKI KAR  
GÖDÖLLŐ



# Napenergiás szárító (SZIE, Gödöllő)



SZENT ISTVÁN  
EGYETEM

GÉPÉSZMÉRNÖKI KAR  
GÖDÖLLŐ





SZENT ISTVÁN  
EGYETEM

GÉPÉSZMÉRNÖKI KAR  
GÖDÖLLŐ

# Napkollektoros növényházi fűtés kiegészítés (SZIE, Gödöllő)



# Transzparens szigetelésű fal (SZIE, Gödöllő)



SZENT ISTVÁN  
EGYETEM

GÉPÉSZMÉRNÖKI KAR  
GÖDÖLLŐ





SZENT ISTVÁN  
EGYETEM

GÉPÉSZMÉRNÖKI KAR  
GÓDÖLLŐ

# Fototermikus naperőmű (Plataforma Solar de Almeria, Spanyolország)

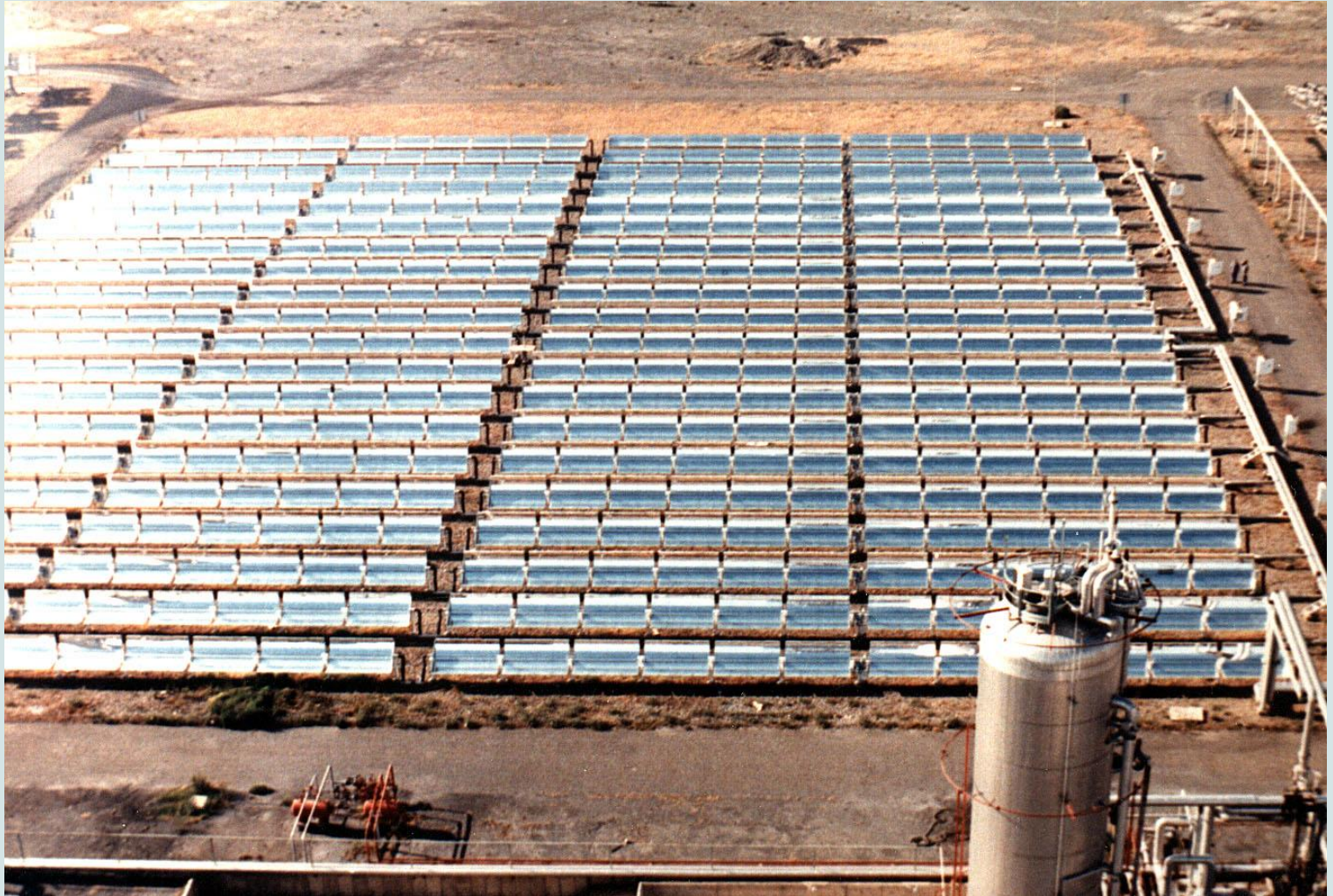



# Fototermikus naperőmű irányítási algoritmus (Plataforma Solar de Almeria, Spanyolország)

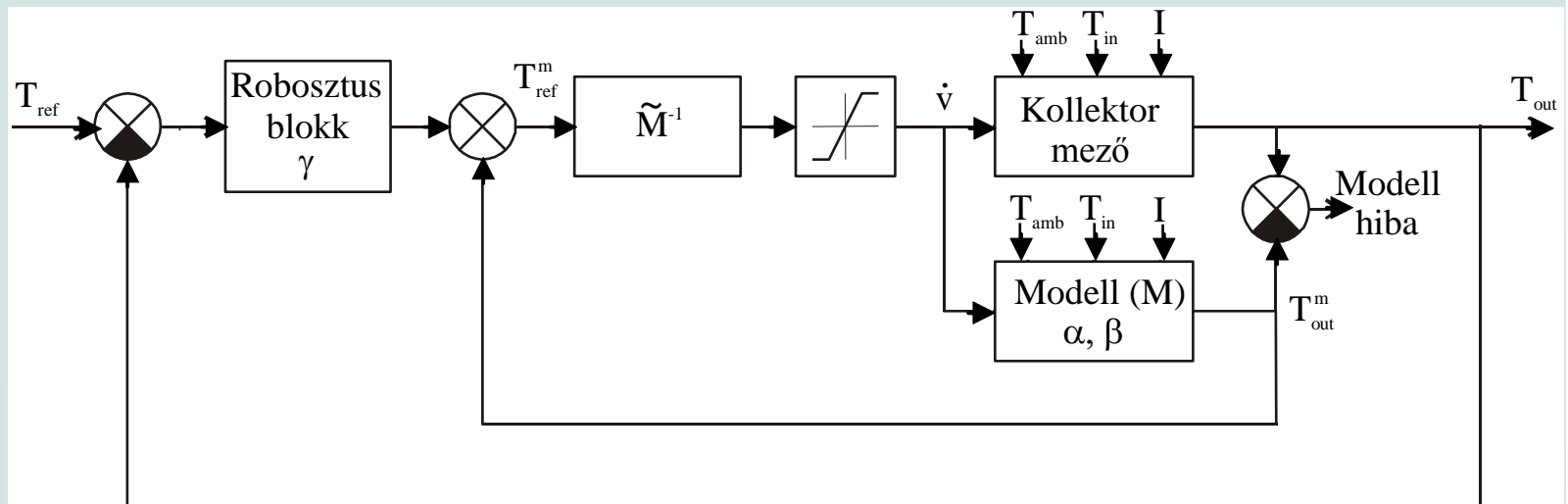



SZENT ISTVÁN  
EGYETEM

GÉPÉSZMÉRNÖKI KAR  
GÖDÖLLŐ

# Hordozható PV kit





# 10 kWp-os hálózatra kapcsolt PV erőmű (SZIE, Gödöllő)

SZENT ISTVÁN  
EGYETEM

GÉPÉSZMÉRNÖKI KAR  
GÖDÖLLŐ







# Különböző PV-s technológiák hatásfokának spektrális vizsgálata

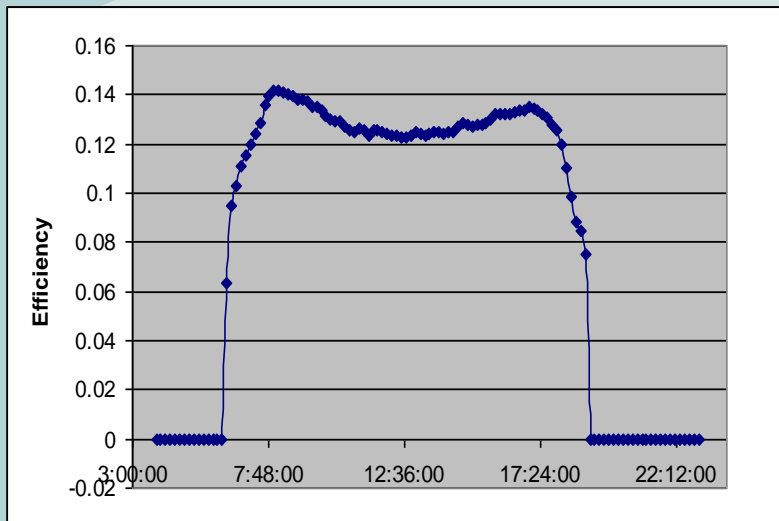

**Polikristályos szilícium**

**Amorf szilícium**

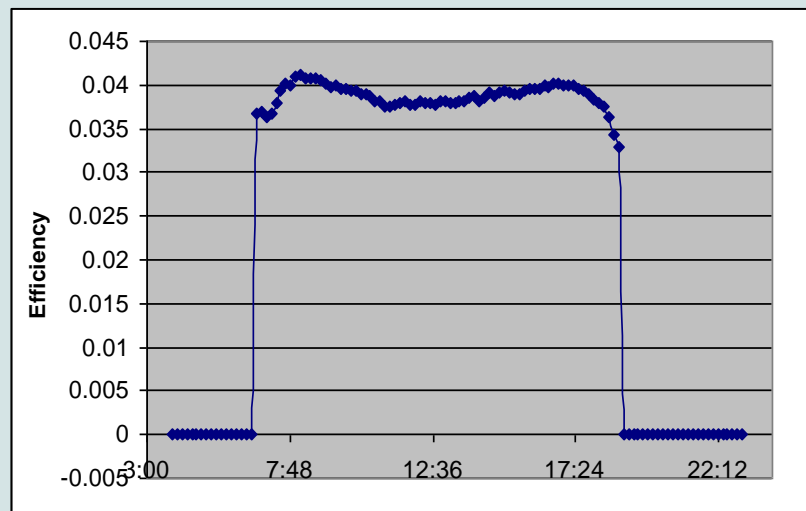



# Összefoglalás

- **Első fototermikus és fotovillamos installáció 1994-ben**
- **1994-től évente Nap Napja, és Energy and Environment Workshop programok szervezése**
- **41 kutatási projekt, amelyből 9 EU-s illetve 11 további nemzetközi projekt**
- **Referált tudományos közlemények száma kb: 500, közülük 90 lektorált folyóiratcikk, amelyből 37 if-es**
- **14 védett PhD dolgozat, ebből 3 külföldi állampolgár**
- **Napenergia kurzusok magyar és angol nyelven**
- **Közreműködő külföldi intézmények: több mint 15**
- **Számos hazai és nemzetközi szakmai szervezeti megbízás**





SZENT ISTVÁN  
EGYETEM

GÉPÉSZMÉRNÖKI KAR  
GÖDÖLLŐ

**Köszönöm a megtisztelő figyelmet!**

